

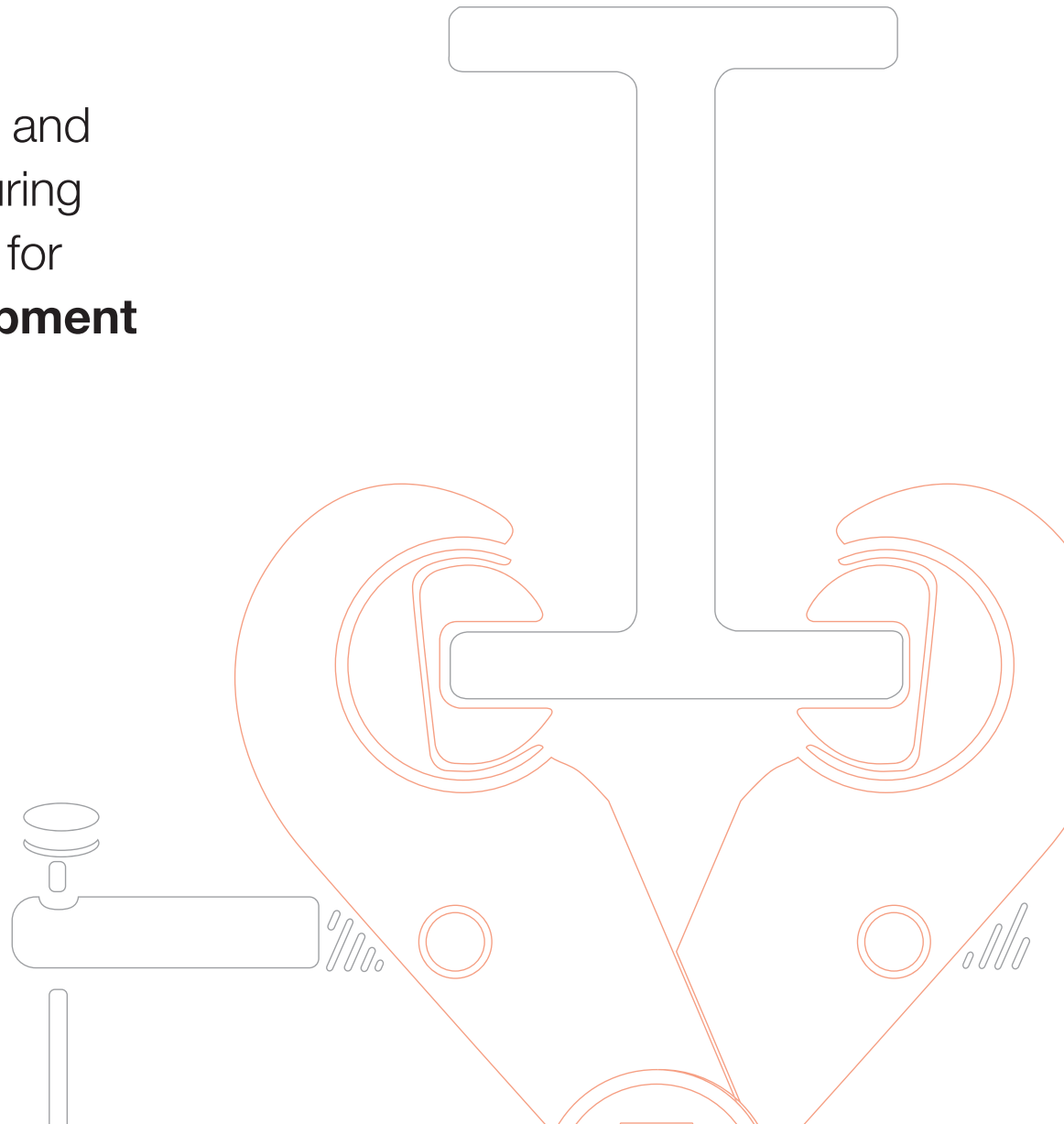

Stationary,
Transferable and
Mobile Securing
Attachments for
Lifting Equipment



INTRODUCTION

EXCELLENCE IN DESIGN

The 'SUPERCLAMP' Trade Mark is synonymous with excellence in practical design, effective safety and assured quality control. 'SUPERCLAMP' products are engineered with the aim to provide efficiency and durability.

Substantial user input has been provided since our last publication, enabling our company to ensure that 'SUPERCLAMP' products have been significantly improved and the product range expanded to meet ever increasing user requirements. Always on the look-out for improvement, our company has successfully proved in less than a decade that 'SUPERCLAMP' products are some of the most cost effective labour and time saving lifting devices of this type on the world market today.

We are committed to developing the most easy-to-use practical lifting tools ever available, keeping safety, speed of application and user requirements in mind as guidelines for future innovations. With the expertise and professional support of our mutual international stockist distributor network, we listen - act - and supply.

Riley (Lifting Equipment) Ltd

'SUPERCLAMP' Distributor Stamp



CONTENTS

| | | |
|---|---|---|
| Permanently Fixed 'SUPERCLAMP' Adjustable Girderclamps <i>Incorporating Lifting Eye and Adjusting Bar.</i> PFC1, PFC2 | 1 | Adjustable 'SUPERCLAMP' Runway Beam Trolleys 6 <i>Incorporating Wheelguarding Anti-Drop Plates, Width Adjusting and Lifting Shackle.</i> BA1, BA2, BA3, B1, B2, B3 |
| Fixed Jaw 'SUPERCLAMP' Adjustable Girderclamps 1 <i>Incorporating Adjusting Mechanism and Lifting Shackle.</i> S1, S2, S2A, S2AX, S3, S3X, S3A, S4, S4S, S4A, S12, S14 | 1 | Adjustable 'SUPERCLAMP' Geared Runway Beam Trolleys 7 <i>Incorporating Wheelguarding Anti-Drop Plates, Width Adjusting and Chain Wheel, Chain, and Lifting Shackle.</i> GBT1, GBT2, GBT3, GBT4, GBT5 |
| Swivel Jaw 'SUPERCLAMP' Adjusting Girderclamps 2 <i>Incorporating Machined Jaw, Adjusting Mechanism and Lifting Shackle.</i> S5, S5A, S6, S6A, S11 | 2 | Autolock 'SUPERCLAMP' Runway Beam Trolley 7 <i>Incorporating Wheelguarding Anti-Drop Plates, Lifting Shackle.</i> A1, A2, A3 |
| Fixed Jaw 'SUPERCLAMP' Adjustable Girderdogs 2 <i>Incorporating Adjusting Mechanism and Lifting Shackle.</i> S15, S16, S17, S18, S19, S20 | 2 | Plate Lifting Clamp 7 <i>Incorporating Locking Mechanism.</i> PLC1, PLC2, PLC3, PLC4 |
| Adjustable Double Ended 'SUPERCLAMP' Monorail Construction Clamp 3 <i>Incorporating Stationary Height Stabiliser Block.</i> S7, S8 | 3 | Adjustable 'SUPERCLAMP' Push Travel Trolley 8 <i>Incorporating adjustment by turning load shaft.</i> PT1, PT2, PT3, PT4, PT5, PT6, PT7 |
| Adjustable Double Ended 'SUPERCLAMP' Monorail Construction Clamp 3 <i>Incorporating Height Adjustment Mechanism.</i> S7A, S8A | 3 | ES 'SUPERCLAMP' Adjustable Girderclamps 8 ES1, ES2, ES3, ES4, ES5, ES6, ES7 |
| 'SUPERCLAMP' Horizontal Plate Lifting Clamps 4 <i>Incorporating Lifting Shackle.</i> HPC1, HPC2, HPC3, HPC4 | 4 | 'SUPERCLAMP' Pipe Hooks 8 <i>Incorporating Lifting Shackle.</i> PH1, PH2, PH3, PH4, PH5 |
| Adjustable 'SUPERCLAMP' Angle Section Clamps 4 <i>Incorporating 'V-Block' Clamping Jaw.</i> AC1, AC2, AC3, AC4 | 4 | Universal 'SUPERCLAMP' 9 <i>For side load applications where conventional 'SUPERCLAMPS' are unsuitable.</i> USC3A, USC4, USC5, USC5D |
| Adjustable 'SUPERCLAMP' Pipe and Round Section Lifting Clamps 5 <i>Incorporating Lifting Shackle and Adjusting Mechanism.</i> P1, P2, P3, P4, P5, P6, P7, P8, P9 | 5 | Adjustable Double Sided 'SUPERCLAMP' 10 <i>Incorporating Adjustable Mechanism.</i> EL1, ELL1 |
| Adjustable 'SUPERCLAMP' Bulb Flats Section Clamps 5 <i>Incorporating Hardened Jaws, Adjusting Mechanism and Lifting Shackle.</i> BFC1, BFC2 | 5 | Procedure for Replacing Worn and Damaged Parts - all Girderclamps 11 |
| Adjustable 'SUPERCLAMP' Rail Lifting Clamps 6 <i>Incorporating Adjusting Mechanism and Lifting Shackle.</i> R1, R2 | 6 | Procedure for Replacing Worn and Damaged Parts - all Beam Trolleys 12 |
| | | Safety and Health 13 |
| | | Additional Information 14 |
| | | Guidelines for the Inspection and Safe Use of 'SUPERCLAMP' Equipment Special Products 15/16 |
| | | Notes 16 |

PERMANENTLY FIXED 'SUPERCLAMP' ADJUSTABLE GIRDERCLAMPS

Incorporating Lifting Eye and Adjusting Bar.

PFC1, PFC2

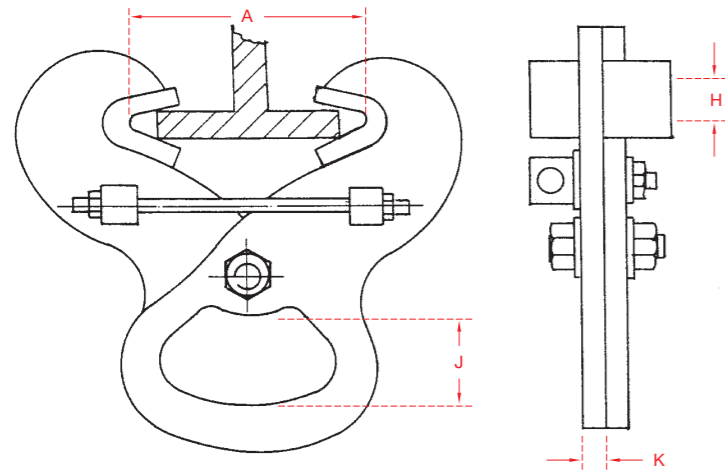

| MODEL | WLL at 0° Vertical | | A Jaw Grip Adjustment | | H Jaw Aperture | | J Lifting Eye Vertical Aperture | | K Sideplate Thickness | Average Weight | |
|-------|--------------------|------|-----------------------|------------|----------------|----|---------------------------------|----|-----------------------|----------------|-----|
| | Lbs | Kg | inch min-max | mm min-max | inch | mm | inch | mm | mm | Lbs | Kg |
| PFC1 | 2240 | 1016 | 3" - 7 1/2" | 76 - 190 | 7/8" | 22 | 1 1/2" | 38 | 6 | 4.0 | 2.0 |
| PFC2 | 4480 | 2032 | 3" - 7 1/2" | 76 - 190 | 7/8" | 22 | 1 1/2" | 38 | 8 | 5.5 | 2.5 |

FIXED JAW 'SUPERCLAMP' ADJUSTABLE GIRDERCLAMPS

Incorporating Adjusting Mechanism and Lifting Shackle.

S1, S2, S2A, S2AX, S3, S3X, S3A, S4, S4S, S4A, S12, S14

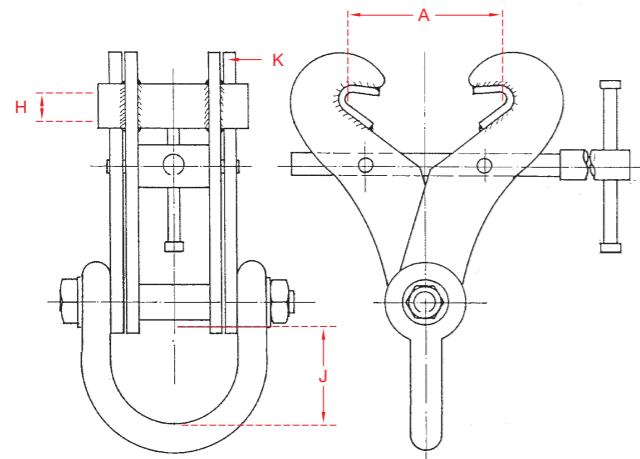

| MODEL | WLL at 0° Vertical | | A Jaw Grip Adjustment | | H Jaw Aperture | | J Inside Shackle Crown to Spacer | | K Sideplate Thickness | Average Weight | |
|-------|--------------------|-------|-----------------------|------------|----------------|----|----------------------------------|-----|-----------------------|----------------|------|
| | Lbs | Kg | inch min-max | mm min-max | inch | mm | inch | mm | mm | Lbs | Kg |
| S1 | 4480 | 2032 | 3" - 7 1/2" | 76 - 190 | 7/8" | 22 | 3 3/4" | 95 | 3.0 | 8.8 | 4.0 |
| S2 | 6720 | 3048 | 3" - 7 1/2" | 76 - 190 | 7/8" | 22 | 3 3/4" | 95 | 6.0 | 11.0 | 5.0 |
| S2A | 6720 | 3048 | 3" - 7 1/2" | 76 - 190 | 7/8" | 22 | 3 3/4" | 95 | 12.5 | 17.6 | 8.0 |
| S2AX | 6720 | 3048 | 5" - 13 3/4" | 127 - 350 | 7/8" | 22 | 3 3/4" | 95 | 12.5 | 25.3 | 11.5 |
| S3 | 8960 | 4064 | 6" - 10" | 150 - 254 | 7/8" | 22 | 3 9/10" | 99 | 10.0 | 24.3 | 11.0 |
| S3X | 11200 | 5080 | 3" - 7 1/2" | 76 - 190 | 7/8" | 22 | 4 | 105 | 12.5 | 22.0 | 10.0 |
| S3A | 11200 | 5080 | 6" - 12" | 150 - 305 | 1 1/4" | 32 | 4 | 105 | 12.5 | 33.0 | 15.0 |
| S4 | 15680 | 7112 | 4" - 9" | 101 - 228 | 1 5/8" | 42 | 5 | 130 | 12.5 | 38.5 | 17.5 |
| S4S | 13440 | 6096 | 8" - 18" | 203 - 457 | 1 5/8" | 42 | 4 1/8" | 105 | 12.5 | 42.0 | 19.0 |
| S4A | 22400 | 10160 | 8" - 18" | 203 - 457 | 1 5/8" | 42 | 5 | 130 | 20.0 | 60.6 | 27.5 |
| S12 | 33560 | 15240 | 8" - 18" | 203 - 457 | 2" | 50 | 7 | 185 | 20.0 | 109.0 | 49.5 |
| S14 | 33560 | 15240 | 16" - 24" | 406 - 610 | 2 1/2" | 63 | 7 | 185 | 20.0 | 129.0 | 58.5 |

UK and Foreign Patents, Registered Designs, Granted and Pending.

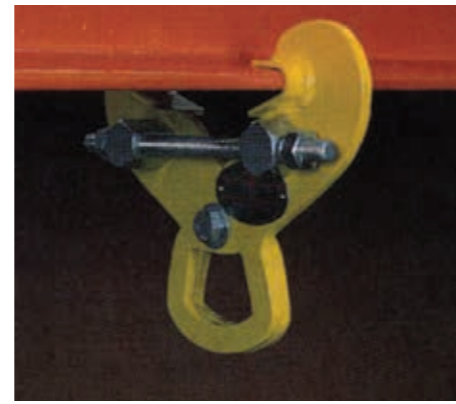

These girderclamps are designed for light industrial applications; particularly where a permanent overhead anchor point is required.

These **high strength inexpensive lightweight clamps** are excellent for application in small garages and hobbyist workshops.

As with all 'SUPERCLAMP' products each PFC unit is proof loaded and supplied with a certificate of test and inspection.



These girderclamps are truly versatile in application and may be used for lifting, pulling, or as an anchor point. Designed specifically to provide maximum **jaw grip adjustment**.

These products are **engineered for practical use where mobility is essential**. The clamps are speedily applied and do not require additional tools or width adjusting components, such as spacing washers. The left and right hand threaded adjusting bar ensures a secure grip on the beam flange.

SWIVEL JAW 'SUPERCLAMP' ADJUSTING GIRDERCLAMPS

Incorporating Machined Jaw, Adjusting Mechanism and Lifting Shackle.

S5, S5A, S6, S6A, S11

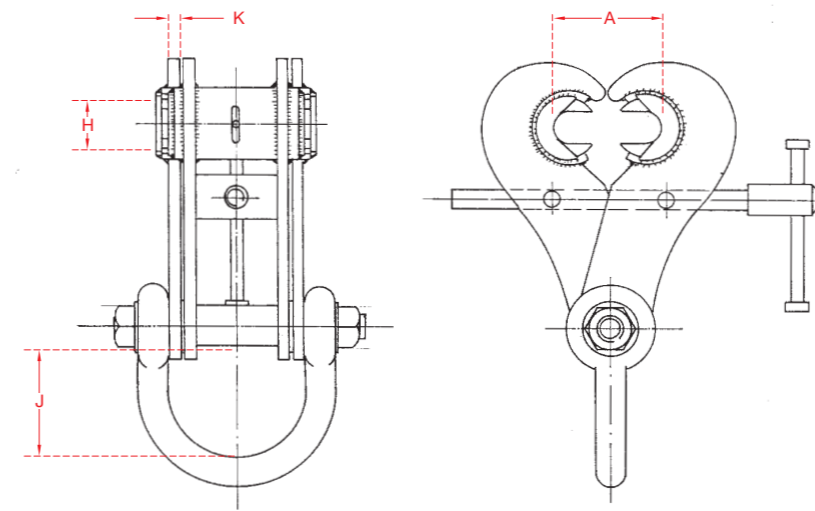

| MODEL | WLL at 0° Vertical | | A Jaw Grip Adjustment | | H Jaw Aperture | | J Inside Shackle Crown to Spacer | | K Sideplate Thickness | Average Weight | |
|-------|--------------------|-------|-----------------------|------------|----------------|------|----------------------------------|-----|-----------------------|----------------|------|
| | Lbs | Kg | inch min-max | mm min-max | inch | mm | inch | mm | mm | Lbs | Kg |
| S5 | 6720 | 3048 | 3 1/2" - 12" | 89 - 305 | 1" | 25.4 | 3 3/4" | 95 | 6.0 | 22.0 | 10.0 |
| S5A | 6720 | 3048 | 3 1/2" - 12" | 89 - 305 | 1" | 25.4 | 4" | 105 | 10.0 | 30.8 | 14.0 |
| S6 | 11200 | 5080 | 3 1/2" - 12" | 89 - 305 | 1" | 25.4 | 4" | 105 | 10.0 | 30.8 | 14.0 |
| S6A | 11200 | 5080 | 3 1/2" - 12" | 89 - 305 | 1" | 25.4 | 4" | 105 | 12.5 | 33.0 | 15.0 |
| S11 | 22400 | 10160 | 3 1/2" - 12" | 89 - 305 | 1" | 25.4 | 5" | 130 | 20.0 | 47.4 | 21.5 |

FIXED JAW 'SUPERCLAMP' ADJUSTABLE GIRDERDOGS

Incorporating Adjusting Mechanism and Lifting Shackle.

S15, S16, S17, S18, S19, S20

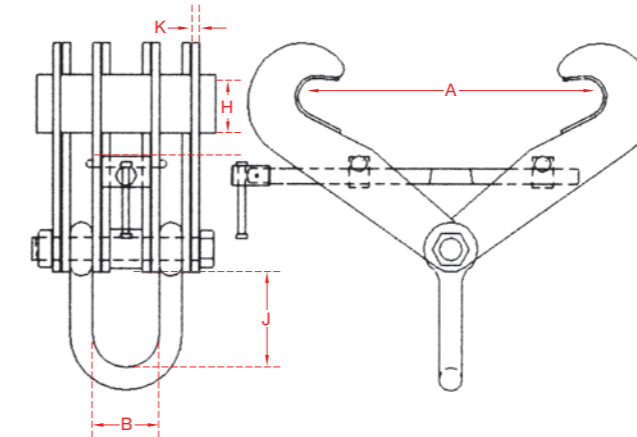

| MODEL | WLL at 0° Vertical | | A Jaw Grip Adjustment | | H Jaw Aperture | | J Inside Shackle Crown to Spacer | | B Inside Shackle Width | | K Sideplate Thickness | Average Weight | |
|-------|--------------------|-------|-----------------------|------------|----------------|----|----------------------------------|-----|------------------------|-----|-----------------------|----------------|-------|
| | Lbs | Kg | inch min-max | mm min-max | inch | mm | inch | mm | inch | mm | mm | Lbs | Kg |
| S15 | 44800 | 20320 | 8" - 18" | 203 - 457 | 2" | 51 | 8 1/4" | 210 | 4 1/2" | 114 | 12.5 | 144.0 | 65.5 |
| S16 | 44800 | 20320 | 16" - 24" | 406 - 610 | 2 1/2" | 63 | 8 1/4" | 210 | 4 1/2" | 114 | 12.5 | 174.0 | 79.0 |
| S17 | 56000 | 25400 | 8" - 18" | 203 - 457 | 2" | 51 | 8 5/8" | 219 | 5" | 127 | 15.0 | 166.0 | 75.5 |
| S18 | 56000 | 25400 | 16" - 24" | 406 - 610 | 2 1/2" | 63 | 8 5/8" | 219 | 5" | 127 | 15.0 | 199.5 | 90.5 |
| S19 | 67200 | 30480 | 8" - 18" | 203 - 457 | 2 1/2" | 63 | 8 5/8" | 219 | 5" | 127 | 20.0 | 202.8 | 92.0 |
| S20 | 67200 | 30480 | 16" - 24" | 406 - 610 | 3" | 76 | 7" | 185 | 5" | 127 | 20.0 | 235.0 | 107.0 |

UK and Foreign Patents, Registered Designs, Granted and Pending.



Swivel jaw adjustable girderclamps incorporate the additional benefit of **horizontal jaw adjustment**.

This enables the full length and a maximum width of the swivel jaw to **anchor evenly** on a considerable surface area of the beam flange.

The 'Swivel Jaw' range of 'SUPERCLAMP' products are designed to ensure **ease of application**.

Additional tools or width adjusting components are not required since the left and right hand threaded adjusting bar will adjust to the jaw grip from 89mm to 305mm (3 1/2" to 12").



'SUPERCLAMP' **Girderdogs** incorporate all the reputedly excellent and reliable design features for which our products are known.

The **Girderdogs** design is enhanced by a well balanced distribution of sideplates, ensuring maximum grip and hold over an adequate length of girder or beam flange.

They are safe in use, and once in position, are speedily applied to a steel beam.

No additional width adjusting tools or components are required.

ADJUSTABLE DOUBLE ENDED 'SUPERCLAMP' MONORAIL CONSTRUCTION CLAMP

Incorporating Stationary Height Stabilizer Block

S7, S8

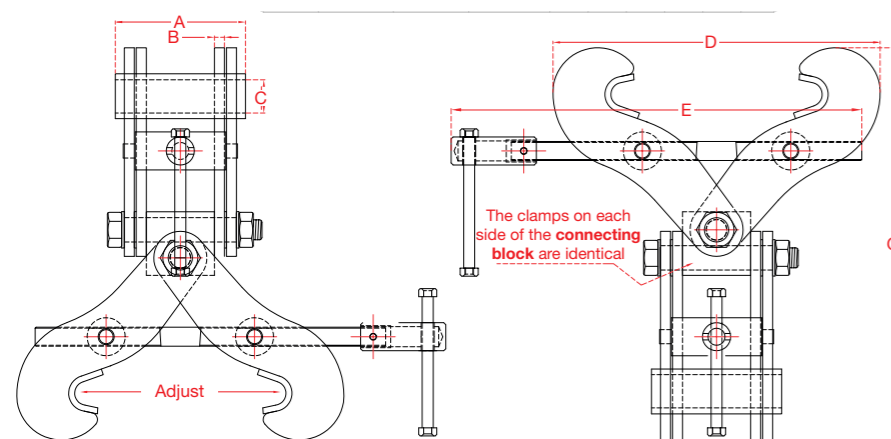

| MODEL | WLL | | A Jaw Grip Adjustment | | DIMENSIONS | | | | | | Average Weight | |
|-------|------|------|--------------------------|---------|------------|----|----|-----|-----|-----|----------------|----|
| | Lbs | Kg | inch | mm | A | B | C | D | E | G | Lbs | Kg |
| S7 | 6720 | 3048 | 3-7 1/2" | 76-190 | 120 | 6 | 22 | 188 | 275 | 298 | | |
| S8 | 8960 | 4064 | 6-10" | 150-254 | 130 | 10 | 22 | 327 | 410 | 392 | | |



These monorail construction clamps are designed to enable **speedy erection of permanent or temporary overhead conveying systems**, where existing steel girders are of an adequately balanced horizontal level. Both clamps are fully adjustable by operating the left and right hand threaded adjusting bars incorporated into the unit. The designed-in **stationary height stabiliser block** ensures a rigid construction of the unit. Additional tools or width adjusting components are not required to apply the unit onto existing steel girders.

ADJUSTABLE DOUBLE ENDED 'SUPERCLAMP' MONORAIL CONSTRUCTION CLAMP

Incorporating Height Adjustment Mechanism.

S7A, S8A

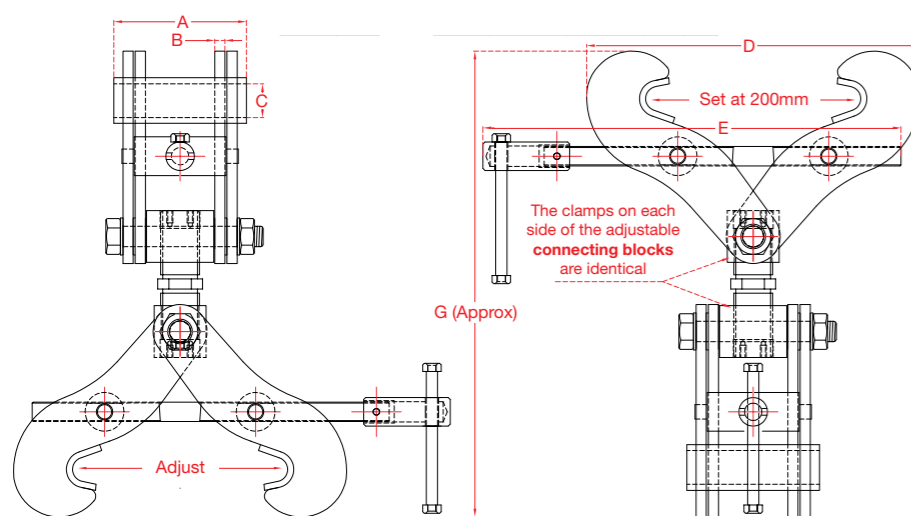

| MODEL | WLL | | A Jaw Grip Adjustment | | DIMENSIONS | | | | | | Average Weight | |
|-------|------|------|--------------------------|---------|------------|----|----|-----|-----|-----|----------------|----|
| | Lbs | Kg | inch | mm | A | B | C | D | E | G | Lbs | Kg |
| S7A | 6720 | 3048 | 3-7 1/2" | 76-190 | 120 | 6 | 22 | 188 | 275 | 366 | | |
| S8A | 8960 | 4064 | 6-10" | 150-254 | 130 | 10 | 22 | 327 | 410 | 457 | | |



Monorail construction clamps incorporating a **height adjusting mechanism** are speedily applied to existing steel girders, so as to expedite erection of a conveying system. They are provided with the facility to adjust the conveying girder in height where required. Their width and height adjusting capabilities make these versatile units **an inexpensive, safe, and time saving proposition** for the construction of a reliable permanent or temporary overhead conveying system.

'SUPERCLAMP' HORIZONTAL PLATE LIFTING CLAMPS

Incorporating Lifting Shackle

HPC1, HPC2, HPC3, HPC4

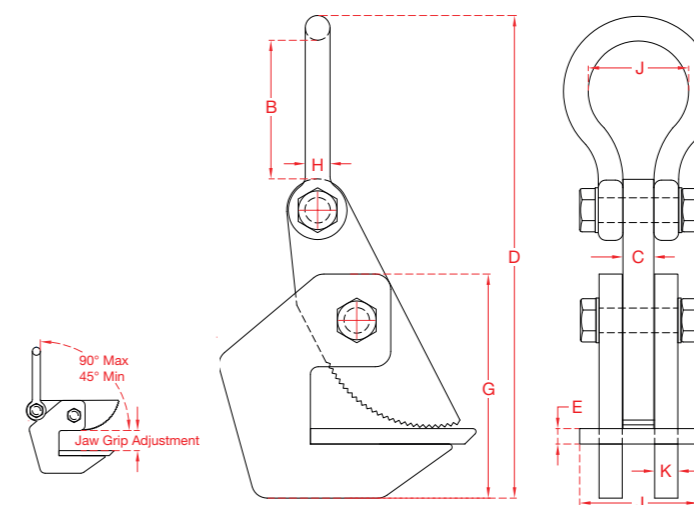

| MODEL | WLL | | DIMENSIONS | | | | | | | | | Average Weight | |
|-------|------|------|------------|-----|----|-----|------|-----|----|----|----|----------------|------|
| | Lbs | Kg | A | B | C | D | E | G | H | J | K | Lbs | Kg |
| HPC1 | 3360 | 1524 | 65 | 90 | 20 | 312 | 10 | 145 | 16 | 76 | 15 | 26.5 | 12.0 |
| HPC2 | 4480 | 2032 | 65 | 90 | 20 | 140 | 10 | 145 | 16 | 76 | 15 | 30.9 | 14.0 |
| HPC3 | 6720 | 3048 | 86 | 135 | 25 | 463 | 12.5 | 214 | 20 | 90 | 20 | 63.9 | 29.0 |
| HPC4 | 8960 | 4064 | 86 | 135 | 25 | 523 | 12.5 | 271 | 20 | 90 | 20 | 90.4 | 41.0 |

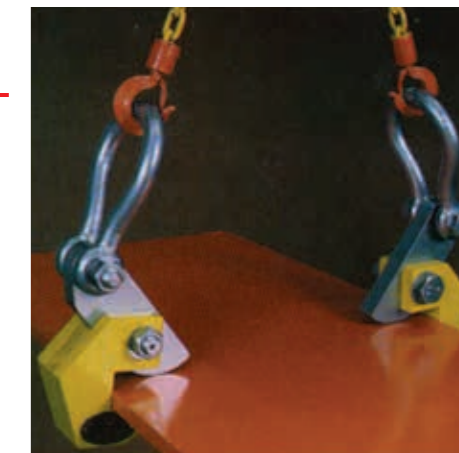

Horizontal plate lifting clamps are designed to be used as **original 'SUPERCLAMP' pairs only**.

Their rigidly competent designs incorporate **an easily replaceable toothed cam toe** which **ensures maximum grip and hold**. The standard jaw apertures allow for a wide range of mild steel plate thickness to be horizontally lifted. Parts are easily replaceable.

'SUPERCLAMP' horizontal plate lifting clamps are equipped with a lifting shackle, and **easily replaceable components**.

ADJUSTABLE 'SUPERCLAMP' ANGLE SECTION CLAMPS

Incorporating 'V-Block' Clamping Jaw.

AC1, AC2, AC3, AC4

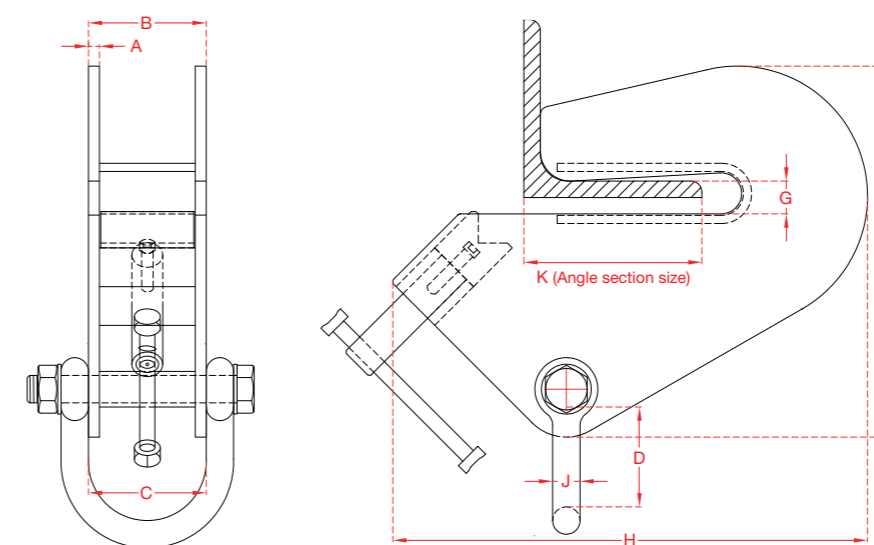

| MODEL | WLL | | DIMENSIONS | | | | | | | | | Average Weight | |
|-------|------|------|------------|----|-----|-----|-----|------|-----|----|---------|----------------|------|
| | Lbs | Kg | A | B | C | D | E | G | H | J | K | Lbs | Kg |
| AC1 | 1120 | 508 | 4 | 65 | 70 | 96 | 206 | 15 | 258 | 16 | 38-101 | 9.9 | 4.5 |
| AC2 | 2240 | 1016 | 6 | 69 | 70 | 96 | 206 | 15 | 258 | 16 | 38-101 | 12.1 | 5.5 |
| AC3 | 3360 | 1524 | 8 | 86 | 90 | 73 | 270 | 19 | 346 | 20 | 50-152 | 24.3 | 11.0 |
| AC4 | 6720 | 3048 | 10 | 90 | 102 | 101 | 343 | 25.4 | 490 | 20 | 101-203 | 47.6 | 21.6 |



This 'SUPERCLAMP' product serves as an anchor or lifting point when attached to an overhead steel angle section approved for lifting applications.

The **'V-Block' clamping jaw** ensures that the clamp is securely fixed to the angle section when adequately tightened.

These clamps are **designed for safety and versatility** - each model being **suitable to accommodate a wide range of steel angle sections**.

No tools required as the **adjusting mechanism** is an integral part of the design features, and **incorporates an adjusting bar with handle**.

ADJUSTABLE 'SUPERCLAMP' PIPE AND ROUND SECTION LIFTING CLAMPS

Incorporating Lifting Shackle and Adjusting Mechanism.

P1, P2, P3, P4, P5, P6, P7, P8, P9

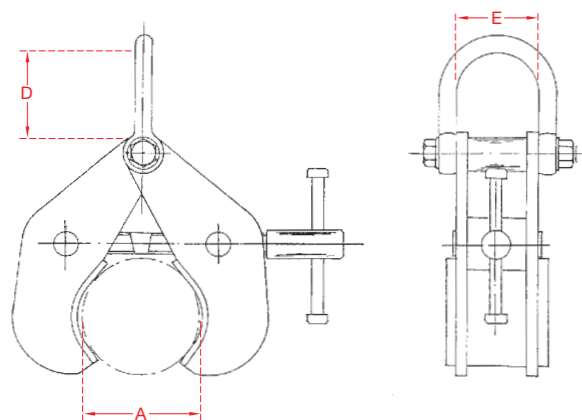

| MODEL | WLL at 0° Vertical | | A Adjustable to Fit Outside Diameter | | D Inside Shackle Crown to Spacer | | E Inside Shackle Width | | Average Weight | |
|-------|--------------------|------|--------------------------------------|------------|----------------------------------|----|------------------------|----|----------------|------|
| | Lbs | Kg | inch min-max | mm min-max | inch | mm | inch | mm | Lbs | Kg |
| P1 | 2240 | 1016 | 2 1/2" - 4 1/2" | 63 - 115 | 3 1/4" | 99 | 2 7/8" | 73 | 15.4 | 7.0 |
| P2 | 3360 | 1524 | 4" - 7" | 101 - 178 | 3 1/4" | 99 | 2 7/8" | 73 | 27.5 | 12.5 |
| P3 | 4480 | 2032 | 5" - 9" | 127 - 228 | 3 1/4" | 99 | 2 7/8" | 73 | 36.3 | 16.5 |
| P4 | 6720 | 3048 | 7" - 11" | 178 - 279 | 5" | 95 | 3 5/8" | 92 | 58.4 | 26.5 |
| P5 | 6720 | 3048 | 8" - 13" | 203 - 330 | 5" | 95 | 3 5/8" | 92 | 69.4 | 31.5 |
| P6 | 6720 | 3048 | 9" - 15" | 228 - 381 | 5" | 96 | 3 5/8" | 92 | 79.4 | 36.0 |
| P7 | 6720 | 3048 | 10" - 17" | 254 - 432 | 5" | 96 | 3 5/8" | 92 | 110.0 | 50.0 |
| P8 | 8960 | 4064 | 12" - 19" | 305 - 482 | 5" | 96 | 3 5/8" | 92 | 140.0 | 63.5 |
| P9 | 8960 | 4064 | 16" - 24" | 406 - 610 | 5" | 96 | 3 5/8" | 92 | 169.0 | 76.5 |

ADJUSTABLE 'SUPERCLAMP' BULB FLATS SECTION CLAMPS

Incorporating Hardened Jaws, Adjusting Mechanism and Lifting Shackle.

BFC1, BFC2

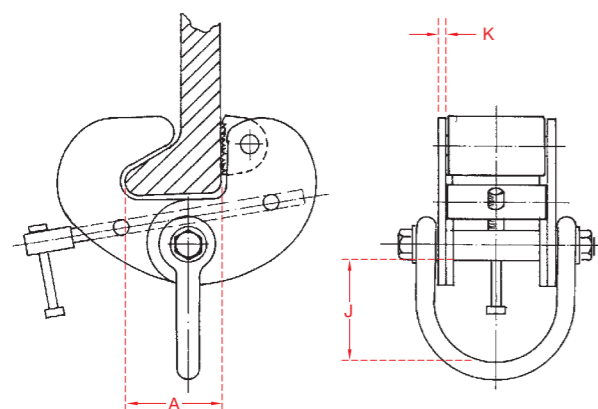

| MODEL | WLL at 0° Vertical | | A Jaw Grip Adjustment | | J Inside Shackle Crown to Spacer | | K Sideplate Thickness | | Average Weight | |
|-------|--------------------|------|--|------------|----------------------------------|----|-----------------------|------|----------------|--|
| | Lbs | Kg | inch min-max | mm min-max | inch | mm | mm | Lbs | Kg | |
| BFC1 | 2240 | 1016 | All sections equivalent or manufactured to BS EN 10067 | | 3 1/2" | 89 | 6.0 | 15.2 | 6.9 | |
| BFC2 | 6720 | 3048 | All sections equivalent or manufactured to BS EN 10067 | | 3 3/4" | 95 | 10.0 | 26.9 | 12.2 | |

UK and Foreign Patents, Registered Designs, Granted and Pending.



'SUPERCLAMP' pipe lifting clamps are designed for **efficient and easy handling** of cylindrical objects such as pipes or bars.

The clamp is **readily applied** to cylindrical objects, and the **adjustable jaw grip** allows for a wide range of cylindrical diameters of sections to be lifted. Also suitable as an anchor point. **No tools required.** The lifting clamp comes complete with **designed-in lifting shackle** and width adjusting mechanism incorporating a left and right hand threaded adjusting bar with handle.



The 'SUPERCLAMP' bulb flats section clamp offers the benefit of maximum adjustability to fit standard dimensions of bulb flats steel sections.

These clamps are primarily developed for a multitude of applications in civil and marine engineering, construction and maintenance.

The adjusting bar secures maximum adjustability, and **eliminates the use of additional tools or width adjusting components.**

All sections equivalent or manufactured to BS EN 10067.

ADJUSTABLE 'SUPERCLAMP' RAIL LIFTING CLAMPS

Incorporating Adjusting Mechanism and Lifting Shackle.

R1, R2

Developed for standard rail sections, the 'SUPERCLAMP' rail lifting clamp provides a **reliable and secure grip on the rail** when tightened. Its **light weight, versatile adjustability** and **low maintenance requirements** makes this 'SUPERCLAMP' product a highly recommendable unit for all engaged in rail construction, rail maintenance and rail manufacture.

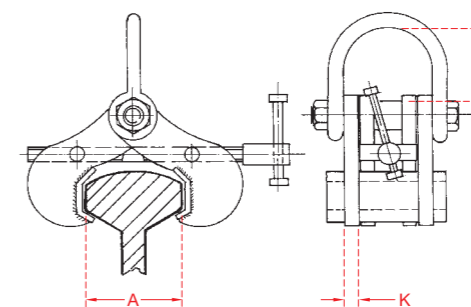

| MODEL | WLL at 0° Vertical | | A Jaw Grip Adjustment | | J Inside Shackle Crown to Spacer | | K Sideplate Thickness | | Average Weight | |
|-------|--------------------|------|-------------------------------------|------------|----------------------------------|-----|-----------------------|------|----------------|--|
| | Lbs | Kg | inch min-max | mm min-max | inch | mm | mm | Lbs | Kg | |
| R1 | 6720 | 3048 | All Standard Rail Sections to 113 A | | 3 3/4" | 95 | 6.0 | 13.2 | 6.0 | |
| R2 | 11200 | 5080 | All Standard Rail Sections to 113 A | | 4" | 105 | 12.5 | 21.0 | 9.5 | |

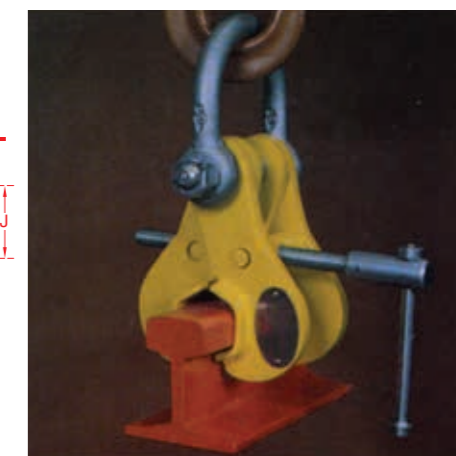

ADJUSTABLE 'SUPERCLAMP' RUNWAY BEAM TROLLEYS

Incorporating Wheelguarding Anti-Drop Plates, Width Adjusting and Lifting Shackle.

BA1, BA2, BA3, B1, B2, B3

This range of lightweight handpush 'SUPERCLAMP' runway beam trolleys offers easy to use mobile securing attachments for load and lifting requirements. Developed for **lighter industrial application**, this product range is completely recommended for maintenance departments and **must be an integrated part of every engineers tool kit.**

The left and right hand threaded adjusting bar only requires turning so as to ensure appropriate adaptation to a beam width, and the trolley is ready for use.

No additional tools or width adjusting components are required.

Fitted with a width adjustment locking mechanism and **wheelguarding anti-drop plates**, this range of products could well be one of the great innovations to secure safety and health in the home workshop and at work.

'SUPERCLAMP' adjustable runway beam trolleys B1, B2 & B3, are of acknowledged and experienced design. The **unique quality features** of this new range of manual travelling gear are the **wheelguarding anti-drop plates**, which are incorporated into the practical design of these transferable and mobile securing attachments. To complement this range, reference is made to 'SUPERCLAMP' geared runway beam trolleys which allow **additional ease of load conveyance.**

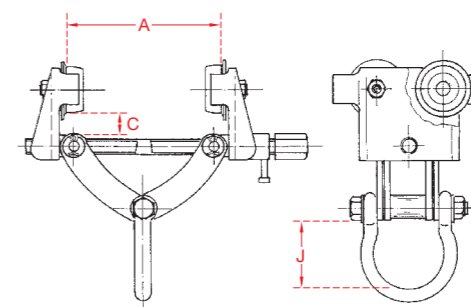

| MODEL | WLL at 0° Vertical | | A Width Adjustment | | C To Accommodate Beam Flange Thickness | | J Inside Shackle Crown to Spacer | | Average Weight | |
|-------|--------------------|------|--------------------|------------|--|------|----------------------------------|-----|----------------|-----|
| | Lbs | Kg | inch min-max | mm min-max | inch | mm | inch | mm | Lbs | Kg |
| BA1 | 2240 | 1016 | 2 1/2" - 8" | 63 - 203 | 1" | 25.4 | 4" | 101 | 14.3 | 6.5 |
| BA2 | 3360 | 1524 | 3" - 8" | 76 - 203 | 1" | 25.4 | 4" | 101 | 15.4 | 7.0 |
| BA3 | 4480 | 2032 | 3" - 8" | 76 - 203 | 1" | 25.4 | 4" | 101 | 15.4 | 7.0 |

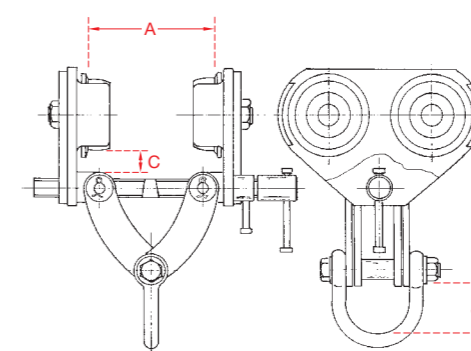

| MODEL | WLL at 0° Vertical | | A Width Adjustment | | C To Accommodate Beam Flange Thickness | | J Inside Shackle Crown to Spacer | | Average Weight | |
|-------|--------------------|-------|--------------------|------------|--|----|----------------------------------|-----|----------------|------|
| | Lbs | Kg | inch min-max | mm min-max | inch | mm | inch | mm | Lbs | Kg |
| B1 | 6720 | 3048 | 3" - 8" | 76 - 203 | 1 1/8" | 28 | 4 1/2" | 115 | 51.8 | 23.5 |
| B2 | 13440 | 6096 | 4" - 12" | 105 - 305 | 1 1/4" | 32 | 4 1/2" | 115 | 110.2 | 50.0 |
| B3 | 22400 | 10160 | 6 1/4" - 12" | 160 - 305 | 1 1/2" | 38 | 4 1/2" | 115 | 164.2 | 74.5 |



UK and Foreign Patents, Registered Designs, Granted and Pending.

ADJUSTABLE 'SUPERCLAMP' GEARED RUNWAY BEAM TROLLEYS

Incorporating Wheelguarding Anti-Drop Plates, Width Adjusting and Chain Wheel, Chain, and Lifting Shackle.

GBT1, GBT2, GBT3, GBT4, GBT5

'SUPERCLAMP' geared runway beam trolleys have taken requirements of the user into consideration. Designed and manufactured with **wheelguarding anti-drop plates**, this product range assures **ease of application in use, maximum safety and hold, and low maintenance requirements**. As with all 'SUPERCLAMP' products, the quality is of the highest standard to comply with user requirements. Standard 3 metre (10ft) drop of chain supplied, extra lengths upon request.

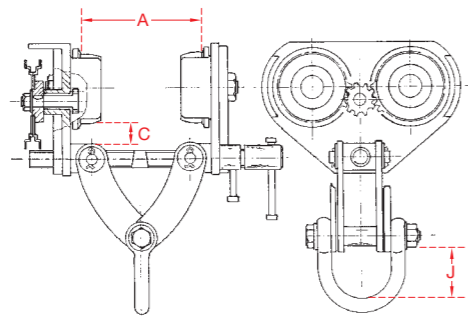

| MODEL | WLL at 0° Vertical | | A Width Adjustment | | C To Accommodate Beam Flange Thickness | | J Inside Shackle Crown to Spacer | | Average Weight | |
|-------|--------------------|-------|--------------------|------------|--|----|----------------------------------|-----|----------------|-------|
| | Lbs | Kg | inch min-max | mm min-max | inch | mm | inch | mm | Lbs | Kg |
| GBT1 | 6720 | 3048 | 3" - 8" | 76 - 203 | 1 1/8" | 28 | 4" | 100 | 68.3 | 31.0 |
| GBT2 | 13440 | 6096 | 4" - 12" | 105 - 305 | 1 1/4" | 31 | 4" | 100 | 126.7 | 57.5 |
| GBT3 | 22400 | 10160 | 6 1/4" - 12" | 160 - 305 | 1 1/2" | 38 | 5 1/8" | 130 | 182.9 | 83.0 |
| GBT4 | 33560 | 15240 | 8" - 18" | 210 - 457 | 3" | 76 | 8 3/4" | 223 | 353.8 | 160.5 |
| GBT5 | 44800 | 20320 | 8" - 18" | 210 - 457 | 3" | 76 | 8 3/4" | 223 | 440.0 | 199.5 |

AUTOLOCK 'SUPERCLAMP' RUNWAY BEAM TROLLEY

Incorporating Wheelguarding Anti-Drop Plates, Lifting Shackle.

A1, A2, A3

A self locking 'SUPERCLAMP' unit with **wheelguarding anti-drop plates** designed for **maximum speed of application, minimum maintenance requirements and maximum safety**.

The **practical and versatile design** provides the user with a **high quality product**, tailored to the needs of those persons who require the use of securing attachments for their lifting operations.

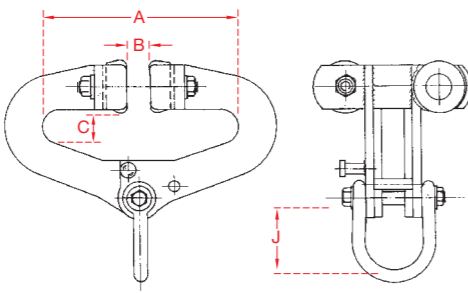

| MODEL | WLL at 0° Vertical | | A Width Adjustment | | C To Accommodate Beam Flange Thickness (max) | | B To Accommodate Flange Web (max) | | J Inside Shackle Crown to Trolley Body | | Average Weight | |
|-------|--------------------|-------|--------------------|------------|--|----|-----------------------------------|----|--|-----|----------------|------|
| | Lbs | Kg | inch min-max | mm min-max | inch | mm | inch | mm | inch | mm | Lbs | Kg |
| A1 | 6720 | 3048 | 3" - 8" | 76 - 203 | 1 1/8" | 28 | 1 3/16" | 30 | 4 1/4" | 110 | 46.3 | 21.0 |
| A2 | 13440 | 6096 | 4" - 12" | 100 - 305 | 1 3/16" | 30 | 1 9/16" | 40 | 5 1/4" | 135 | 72.8 | 33.0 |
| A3 | 22400 | 10160 | 4" - 12" | 100 - 305 | 1 3/16" | 30 | 1 9/16" | 40 | 5 1/4" | 135 | 104.7 | 47.5 |

PLATE LIFTING CLAMP

Incorporating Locking Mechanism.

PLC1, PLC2, PLC3, PLC4

'SUPERCLAMP' Horizontal to Vertical Plate Lifting Clamp has been developed to provide the user with a safe to use and easy to handle plate lifting tool.

The locking mechanism provides an additional safety feature for the operator.

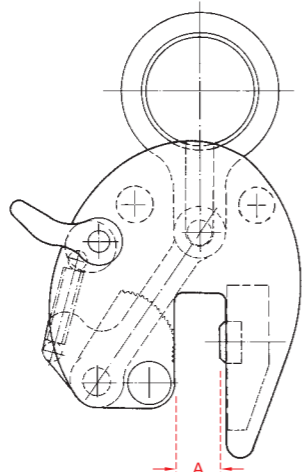

| MODEL | WLL at 0° Vertical | | A Plate Thickness | | Average Weight | |
|-------|--------------------|------|-------------------|------------|----------------|------|
| | Lbs | Kg | inch min-max | mm min-max | Lbs | Kg |
| PLC1 | 2240 | 1016 | 0 - 3/4" | 0 - 20 | 6.6 | 3.0 |
| PLC2 | 4480 | 2032 | 0 - 1 1/4" | 0 - 32 | 14.3 | 6.5 |
| PLC3 | 6720 | 3048 | 0 - 1 1/4" | 0 - 32 | 19.8 | 9.0 |
| PLC4 | 8960 | 4064 | 0 - 1 1/4" | 0 - 32 | 27.6 | 12.5 |

UK and Foreign Patents, Registered Designs, Granted and Pending.

ADJUSTABLE 'SUPERCLAMPS' PUSH TRAVEL TROLLEY

Incorporating adjustment by turning load shaft.

PT1, PT2, PT3, PT4, PT5, PT6, PT7

A **lightweight low cost** push travel trolley with **low headroom anchor point**, makes this a highly recommendable unit for most industrial applications.

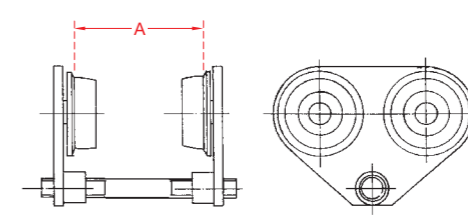

| MODEL | WLL at 0° Vertical | | A Adjustment | | Average Weight | |
|-------|--------------------|------|--------------|------------|----------------|------|
| | Lbs | Kg | inch min-max | mm min-max | Lbs | Kg |
| PT1 | 1120 | 508 | 2" - 7" | 50 - 175 | 12.1 | 5.5 |
| PT2 | 2240 | 1016 | 2" - 7" | 50 - 175 | 16.5 | 7.5 |
| PT3 | 2240 | 1016 | 4" - 10" | 100 - 250 | 16.5 | 7.5 |
| PT4 | 4480 | 2032 | 2" - 7" | 50 - 175 | 18.7 | 8.5 |
| PT5 | 4480 | 2032 | 4" - 10" | 100 - 250 | 19.8 | 9 |
| PT6 | 6720 | 3048 | 2" - 7" | 50 - 175 | 38.6 | 17.5 |
| PT7 | 6720 | 3048 | 4" - 10" | 70 - 175 | 41.9 | 19 |

ES 'SUPERCLAMP' ADJUSTABLE GIRDERCLAMPS

ES1, ES2, ES3, ES4, ES5, ES6, ES7

A **lightweight low cost** girderclamp with **low headroom anchor point**, makes this a highly recommendable unit for most industrial applications.

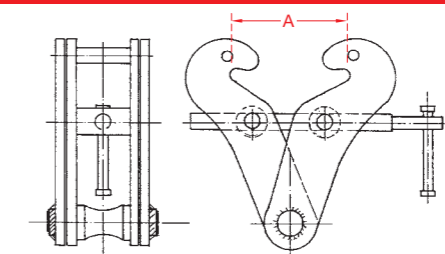

| MODEL | WLL at 0° Vertical | | A Adjustment | | Average Weight | |
|-------|--------------------|------|--------------|------------|----------------|------|
| | Lbs | Kg | inch min-max | mm min-max | Lbs | Kg |
| ES1 | 2240 | 1016 | 2" - 8" | 60 - 200 | 7.7 | 3.5 |
| ES2 | 4480 | 2032 | 2" - 8" | 60 - 200 | 9.9 | 4.5 |
| ES3 | 4480 | 2032 | 4" - 12" | 100 - 300 | 17.6 | 8.0 |
| ES4 | 6720 | 3048 | 2" - 8" | 50 - 200 | 14.3 | 6.5 |
| ES5 | 6720 | 3048 | 4" - 12" | 100 - 300 | 22.0 | 10.0 |
| ES6 | 11200 | 5080 | 2" - 8" | 50 - 200 | 27.5 | 12.5 |
| ES7 | 11200 | 5080 | 4" - 12" | 100 - 300 | 32.0 | 14.5 |

'SUPERCLAMP' PIPE HOOKS

Incorporating lifting shackle.

PH1, PH2, PH3, PH4, PH5

'SUPERCLAMP' pipe hooks are designed to be used in pairs for efficient and easy handling of pipes.

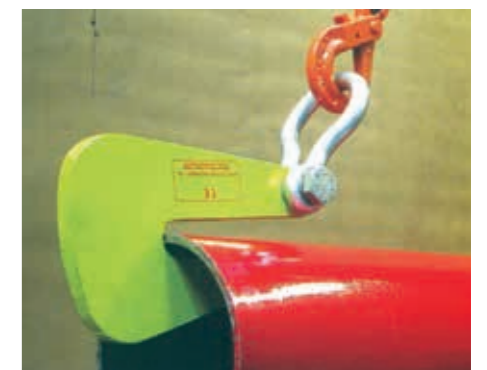
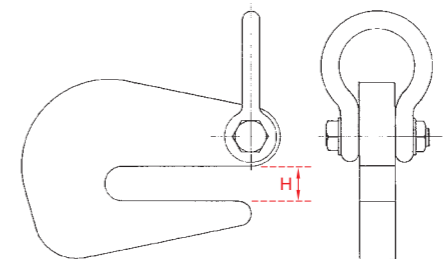

| MODEL | WLL at 0° Vertical | | H Max. Pipe Wall Thickness | | Average Weight (in Pairs) | |
|-------|--------------------|------|----------------------------|------------|---------------------------|------|
| | Lbs | Kg | inch min-max | mm min-max | Lbs | Kg |
| PH1 | 2240 | 1016 | 1" | 25 | 26.5 | 12.0 |
| PH2 | 4480 | 2032 | 1 13/64" | 30 | 35.2 | 16.0 |
| PH3 | 8960 | 4064 | 1 19/32" | 40 | 66.1 | 30.0 |
| PH4 | 13440 | 6096 | 2" | 50 | 77.1 | 35.0 |
| PH5 | 17920 | 8128 | 2 3/4" | 70 | 114.6 | 52.0 |

UK and Foreign Patents, Registered Designs, Granted and Pending.

UNIVERSAL 'SUPERCLAMP'

For side load applications where conventional 'SUPERCLAMPS' are unsuitable.

USC3A, USC4, USC5

The universal 'SUPERCLAMP' has been designed not only for vertical use, but also for **side load applications**, where conventional clamps are not suitable. This clamp is **truly versatile** in application and can be used for **lifting, pulling or as an anchor point**.

It can be loaded at any angle and **eliminates the use of spreader beams** in various lifting operations. With a **low headroom anchor point**, it can be used as a single or twin point lifting, giving **positive grip and quick application** combined with **lightweight construction**.

No additional tools are required.

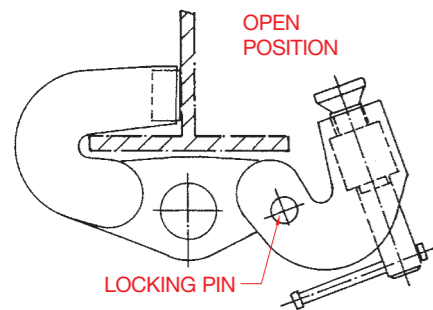
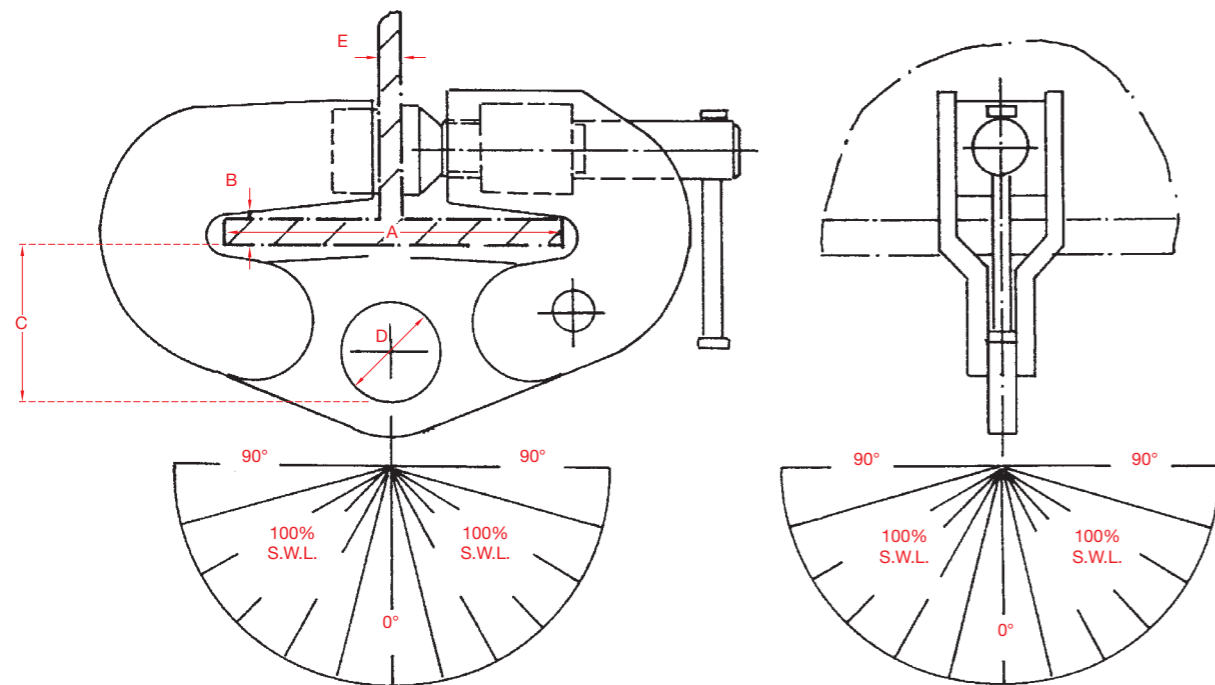
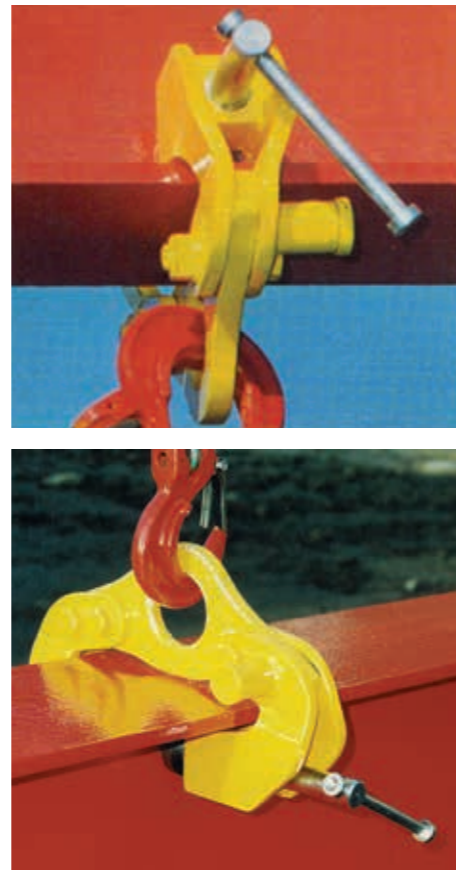

| MODEL | WLL at 0° Vertical | | A Adjustment | | B To Accommodate Beam Flange Thickness (max) | | C Headroom | | D Max. Hook Size | | E Max. Webb Thickness | | Average Weight | |
|-----------|--------------------|-------|------------------|------------|--|------|------------|-----|------------------|----|-----------------------|----|----------------|------|
| | Lbs | Kg | inch min-max | mm min-max | inch | mm | inch | mm | inch | mm | inch | mm | Lbs | Kg |
| USC3A | 6720 | 3048 | 5" - 8" | 125 - 204 | 1" | 25.4 | 4" | 100 | 2 3/4" | 70 | 1 1/4" | 32 | 30 | 13.5 |
| USC4 | 8960 | 4064 | 5" - 12" | 125 - 305 | 1" | 25.4 | 4" | 100 | 2 3/4" | 70 | 1 1/4" | 32 | 51 | 23.5 |
| USC5 | 11200 | 5080 | 5" - 12" | 125 - 305 | 1" | 25.4 | 4 3/4" | 120 | 2 3/4" | 70 | 1 1/4" | 32 | 61.7 | 28 |
| USC5D | 22400 | 10160 | 5" - 12" | 125 - 305 | 1" | 25.4 | 4 3/4" | 120 | 2 3/4" | 70 | 1 1/4" | 32 | 83.8 | 38 |
| USC5D 400 | 22400 | 10160 | 8 7/8" - 15 3/4" | 225 - 400 | 1" | 25.4 | 4 3/4" | 120 | 2 3/4" | 70 | 1 1/4" | 32 | 99.2 | 45 |

WARNING: Do not exceed working load limits or use this equipment for lifting Flat Plate Sections (not to be used as a plate lifting clamp).

UK and Foreign Patents, Registered Designs, Granted and Pending.

ADJUSTABLE DOUBLE SIDED 'SUPERCLAMP'

Incorporating Adjustable Mechanism.

EL1 (Easy Lift)

EL1 is fitted to the top beam flanges and was designed primarily to help reduce the risk of accidents when positioning heavy load bearing equipment to the lower flange. EL1 has lifting points each side and can be used independently or together for a balanced lift. Being of lightweight construction, can be fitted quickly.

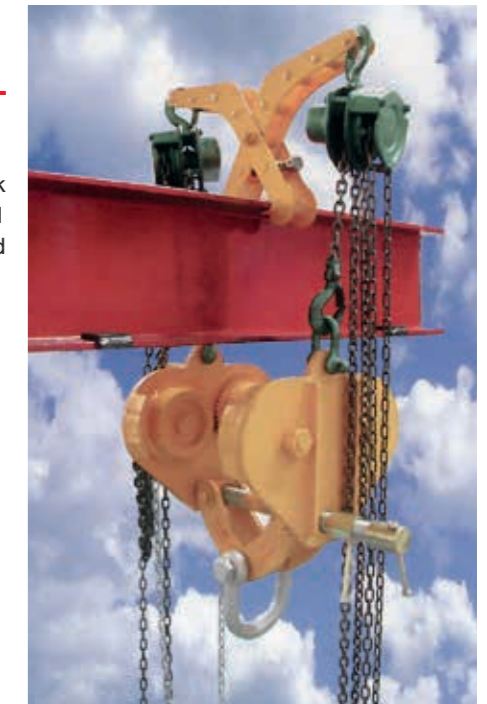
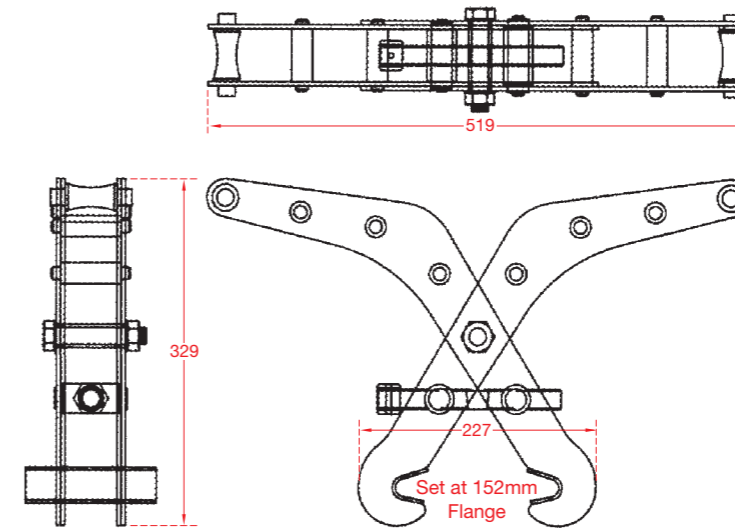

| MODEL | WLL | | WEIGHT | | ADJUST | |
|-------|-----|-----|--------|-----|-------------|---------|
| | Lbs | kg | Lbs | kg | inch | mm |
| EL1 | 440 | 200 | 12.8 | 5.8 | 4 1/2" - 8" | 114-204 |

THE WORK LOAD LIMIT CAN BE APPLIED TO ONE HANGER PIN, THE TWO HANGER PINS WHEN LOADED MUST NOT EXCEED THE WORK LOAD LIMIT

ADJUSTABLE DOUBLE SIDED 'SUPERCLAMP'

For use in limited space above the beam. Incorporating Adjustable Mechanism.

ELL1 (Easy Lift)

For use in limited space above the beam. ELL1 is fitted to the top beam flanges and was designed primarily to help reduce the risk of accidents when positioning heavy load bearing equipment to the lower flange. ELL1 has lifting points each side and can be used independently or together for a balanced lift. Being of lightweight construction, can be fitted quickly.

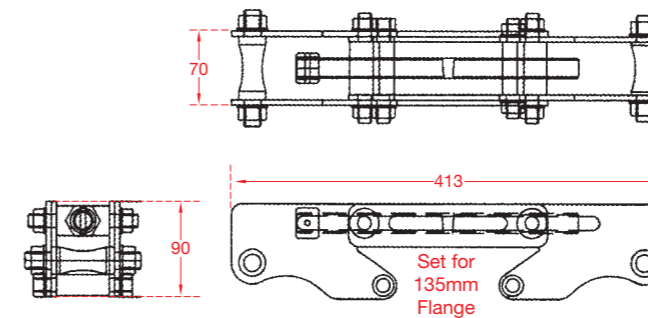

| MODEL | WLL | | WEIGHT | | ADJUST | |
|-------|-----|-----|--------|-----|-------------|---------|
| | Lbs | kg | Lbs | kg | inch | mm |
| ELL1 | 440 | 200 | 12.8 | 5.8 | 4 1/2" - 8" | 114-204 |

THE WORK LOAD LIMIT CAN BE APPLIED TO ONE HANGER PIN, THE TWO HANGER PINS WHEN LOADED MUST NOT EXCEED THE WORK LOAD LIMIT

UK and Foreign Patents, Registered Designs, Granted and Pending.

PROCEDURE FOR REPLACING WORN AND DAMAGED PARTS

TO REPLACE THREADED ADJUSTING SCREW FOR MODELS:

S1 - S20, R1 - R2, P1 - P8, BFC1 - BFC2

STRIP DOWN

- Remove handle securing pin using correct diameter punch, wind off handle.
- Remove shackle pin, wind off left and right hand side frames, (where adjusting screw is damaged it may be necessary to cut away damaged area to allow screw to be removed).
- Check for wear in other parts of clamp.

RE-ASSEMBLE

- Install new adjusting screw winding left and right hand side frames equally to centre land area of screw.
- Replace shackle and shackle bolt, fit new shackle bolt locking nut.
- Wind on handle and secure with new spring pin.
- It is advisable that all parts be well lubricated before being put into place.

TO REPLACE THREADED KNUCKLES FOR MODELS:

S11 - S20

STRIP DOWN

- Remove handle securing pin using correct diameter punch, wind off handle.
- Remove knuckle securing pins.
- Remove knuckle and adjusting screw assembly, wind off old knuckles from adjusting screw.

RE-ASSEMBLE

- Wind on new knuckles left and right hand, ensuring both are equally to centre land area of screw.
- Re-fit onto clamp side frames using securing pins provided.
- Wind on handle and secure with new spring pin, lubricate with grease.

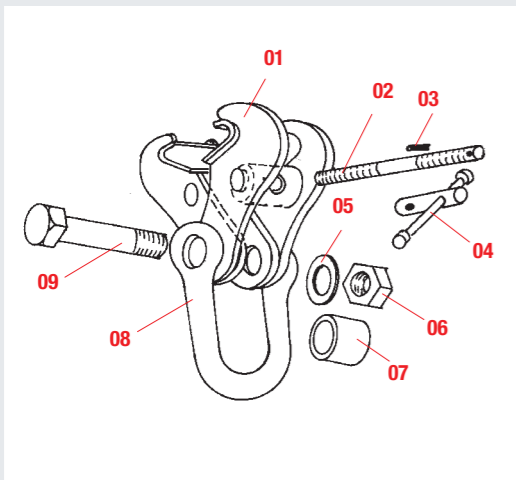

| No. | Description | Qty. |
|-----|-----------------|------|
| 01 | Side Frame | 2 |
| 02 | Adjusting Screw | 1 |
| 03 | Securing Pin | 1 |
| 04 | Handle | 1 |
| 05 | Washer | 4 |
| 06 | Nut | 1 |
| 07 | Spacer | 1 |
| 08 | Shackle | 1 |
| 09 | Bolt | 1 |

PROCEDURE FOR REPLACING WORN AND DAMAGED PARTS

TO REPLACE GEARING FOR MODELS:

GBT1 - GBT5

STRIP DOWN

- Remove locking nut on front of chainwheel.
- The chainwheel is held in position by a woodruff key. Draw chainwheel and chainwheel centre from drive shaft.
- Remove woodruff key from drive shaft.
- Remove drive shaft from wheel plate. Ensure drive shaft bush is not damaged.

RE-ASSEMBLE

- Re-assemble gearing as above in reverse order.

TO REPLACE BEARINGS ON MODELS:

BA1 - BA3, B1 - B3, GBT1 - GBT5, A1 - A3

STRIP DOWN

- Remove wheel and wheel axle from wheelplates.
- Press out axle from bearing.
- Remove internal circlip from back of wheel and press out old bearing.

RE-ASSEMBLE

- Ensure all components are cleaned thoroughly and press in new bearing.
- Replace internal circlip.
- Press wheel axle into bearing (ensuring wheel spins freely on axle).
- Fit completed assembly back onto wheelplate.

TO REPLACE THREADED ADJUSTING SCREW FOR MODELS:

BA1 - BA3, B1 - B3, GBT1 - GBT5

STRIP DOWN

- Remove handle securing pin using correct diameter punch, wind off handle and locking collar.
- Remove shackle pin, wind off left and right hand wheelplates, (it may be necessary to cut away damaged area of adjusting screw to allow screw to be removed).

RE-ASSEMBLE

- Fit new adjusting screw winding left and right hand wheelplates equally to centre land area of screw.
- Replace shackle and shackle pin. Renew shackle pin self locking nut.
- Wind on locking collar and handle. Secure handle with new spring pin. Lubricate with grease.

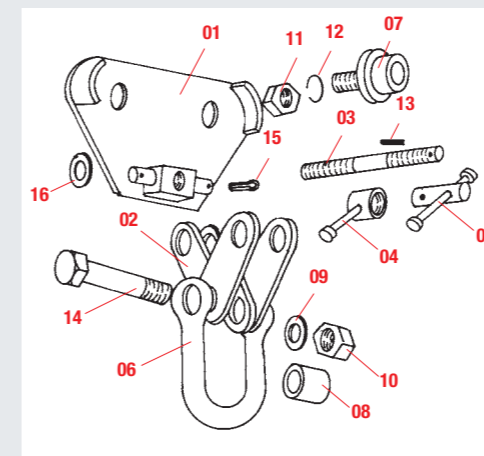

| No. | Description | Qty. | No. | Description | Qty. |
|-----|---------------------------|------|-----|---------------|------|
| 01 | Side Frame | 2 | 09 | Washer | 4 |
| 02 | Link Arm | 4 | 10 | Locking Nut | 1 |
| 03 | Adjusting Screw | 1 | 11 | Plain Nut | 4 |
| 04 | Locking Collar | 1 | 12 | Spring Washer | 4 |
| 05 | Handle | 1 | 13 | Securing Pin | 1 |
| 06 | Shackle | 1 | 14 | Bolt | 1 |
| 07 | Wheel/Spindle/ Bearing | 4 | 15 | Split Pin | 4 |
| 08 | Spacer | 1 | 16 | Washer | 4 |

IMPORTANT INFORMATION

SAFETY AND HEALTH

Suppliers are generally required to make available information relating to articles supplied to ensure that when put to proper use they are safe and without risk to health.

Experience over many years has not shown up any particular problems with regard to Health and Safety in connection with the products we manufacture and supply providing:

- 1 They are used for the purpose for which they were designed.
- 2 They are not loaded beyond their related work load limit.
- 3 They are properly maintained.
- 4 They are regularly inspected and tested in accordance with the relevant statutory regulations.
- 5 They are used by competent persons trained in their applications.

WARNING

Our products are marked with a Maximum Work Load Limit which must not be exceeded. The manufacturers do not accept any liability for damages which may result from the product being used in excess of the Work Load Limit.

Ensure that existing end stops on runway beams will accommodate 'SUPERCLAMP' Trolleys.

On occasions we supply replacement component parts for articles of Lifting Equipment but we do not accept any responsibility for these unless they are installed by a person with appropriate knowledge and ability and the Statutory tests and inspections are carried out on completion of repair.

Unless we are informed at the time of enquiry and order regarding particular hazardous environmental conditions all equipment is supplied on the assumption that it will be used in normal atmospheric and temperature conditions as applicable within the United Kingdom.

WORK LOAD LIMIT

This is the maximum load which can be applied to the product in service.

It is of the utmost importance to Health and Safety to ensure that 'SUPERCLAMP' products are only attached to structures, materials or other lifting components which are authentically and authoritatively approved and recommended to carry or sustain the maximum work load limits to be applied.

ADDITIONAL INFORMATION

Our contribution to SAFETY is in securing the QUALITY and RELIABILITY of our 'SUPERCLAMP' products.

Each 'SUPERCLAMP' product is proof tested to twice the work load limit, unless otherwise stated or required by authoritative recommendations. Tests to destruction ensuring a 5-1 factor of safety are employed throughout the design, development, and manufacturing process of our products where required.

Our distributor network will provide active and consultative support to assist in the selection of safety equipment to suit your lifting gear applications.

Should our range of 'SUPERCLAMP' products not fulfil your immediate requirements, then please contact your nearest authorised 'SUPERCLAMP' supplier who will gladly quote for any special applications.

Descriptions and illustrations in this Technical Data Guide are intended merely to present a general idea of the goods described and do not form the basis of a contract unless specifically confirmed by the manufacturer in writing.

We reserve the right to modify information given in this publication without notice.

'SUPERCLAMP' products are supplied in standard colours - yellow enamel or white semi gloss, unless on special order.

Measurements shown in this publication are approximate averages.

Our Standard Conditions of Sale apply and are available upon request.

Due to our intensive product development programme, specifications may have changed, please check with your 'SUPERCLAMP' distributor before purchase.

SAFE USE OF BEAM CLAMPS

11.1 Beam clamps provide a simple and portable means of attaching a hoist to a runway or lifting beam. They should not be used on any beam other than those designed, test and marked as a runway beam (or lifting beam) with the exception that they may be used on a beam forming part of a structure where a specific design check for this purpose has been made.

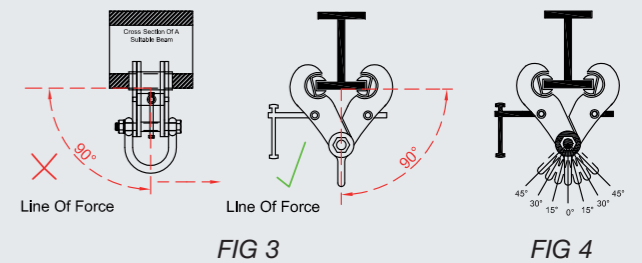

SELECTION

11.2 Beam clamps are available in two basic designs, the clip on type (FIG 1) and the more popular adjustable type (FIG 2).

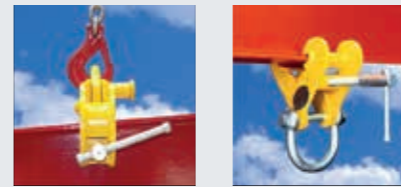

FIG 1

FIG 2

The main consideration when selecting the clamp is the required SWL, i.e. the load to be lifted plus the weight of the hoisting unit.

NOTE: If the clamp is to be used to suspend a shave block, the additional loading caused by the downward pull on the effort rope must be taken into consideration when determining the SWL requirement.

11.3 The width and thickness of the beam flange must also be considered and may well lead to the selection of a clamp in excess of the desired SWL to be compatible with the beam dimensions. The range and adjustability are indicated on the clamp's identification plate.

11.4 The majority of clamps are designed for 'in-line' use only, i.e. the line of force must be at right angles to the flange of the beam on which it is attached (see FIG 3). It is therefore important to ensure that for 'angled' applications, a clamp of suitable design is selected (see FIG 4).

The tables below only apply to selected models of Riley's clamps. Stress calculations should be carried out by the user's engineering department for any/all steelwork from which the clamp will be suspended. The following work load limits and derations have been established specifically for most "S" type clamps and only apply in overhead beam, i.e. do NOT apply if clamps are to be used for lifting beams. (The side load clamp 'USC range' has been specifically designed for this purpose.)

| REDUCTION IN WORKING LOAD LIMITS WHEN SIDE LOADS APPLIED | | | | |
|--|-----------|-----------|------------|------------|
| ANGLE FROM VERTICAL | 0° | 0° to 15° | 15° to 30° | 30° to 45° |
| REDUCTION FACTOR | NIL | 17% | 34% | 50% |
| MODELS | WLL (TON) | WLL (TON) | WLL (TON) | WLL (TON) |
| S3A, S2AX, S5A | 3 | 2.5 | 2 | 1.5 |
| S3 | 4 | 3.3 | 2.6 | 2 |
| S3X, S3A, S6, S6A | 5 | 4.1 | 3.3 | 2.5 |
| S4 | 7 | 5.8 | 4.6 | 3.5 |
| S4S | 6 | 5 | 4 | 3 |
| S4A, S11 | 10 | 8.3 | 6.6 | 5 |
| S12, S14 | 15 | 12.4 | 10 | 7.5 |
| S15, S16 | 20 | 16.6 | 13.2 | 10 |
| S17, S18 | 25 | 20.7 | 16.5 | 12.5 |
| S19, S20 | 30 | 25 | 19.8 | 15 |

Clamp models S1, S2 and S5 are not suitable for any side loading as they are of a lightweight design.

GUIDELINES FOR THE INSPECTION AND SAFE USE OF 'SUPERCLAMP' EQUIPMENT

INSPECTION OF 'SUPERCLAMP' EQUIPMENT

1 GENERAL:

Follow all requirements of laws, rules and regulations applicable in your country pertaining to lifting operations, ensuring all maintenance testing, inspection and operator requirements are strictly adhered to. This is in your interest, and can prevent fatal accidents and industrial disaster.

2 CHECKLIST:

- Is any part of the equipment distorted?
- Are any cracks visible, or is extensive corrosion evident?
- Is any wear evident at suspension points, wheels, shackles, gears, pivots, pins, bolts, threads, springs, or other moving part?
- Are locking arrangements functional and safe?
- Are the work load limit, the serial number and other markings legible?
- Have all inspections or tests been regularly recorded? If not, re-certification should be carried out before use.
- Does the 'SUPERCLAMP' equipment carry its original identification marking?

SAFE USE OF 'SUPERCLAMP' EQUIPMENT

- 1 Ensure that the selected 'SUPERCLAMP' equipment is of a suitable type for the lifting or suspension operation you intend to undertake.
- 2 Ensure that structures to which 'SUPERCLAMP' equipment may be fitted are of adequate design and comply with all legal requirements. Structures designed for lifting operation purposes are usually marked with the maximum Work Load Limit which may be applied. Ensure that structures are test certified to such use and that the appropriate certificate is up to date.
- 3 Never stand beneath a suspended load.
- 4 'SUPERCLAMP' products are primarily designed for in-line use only and the equipment is thus marked. Never use 'SUPERCLAMP' products for sideloading applications unless this is specifically recommended on the original 'SUPERCLAMP' identification marking affixed to the unit. If the identification marking states that the unit must be used at 0° (zero degrees) only, then no side loading/angle loading is permitted. Eg: no single point lifting of beams.
- 5 'SUPERCLAMP' products must not be attached to defective structures or materials. Ensure that runway beams are fitted with end stops and are free from any defects. Should a defect on a runway beam or structural member be observed, remove the 'SUPERCLAMP' unit immediately and report your observations to the person in charge.
- 6 When selecting 'SUPERCLAMP' products, ensure that the calculated Work Load Limit requirement allows for any additional weight of equipment which may be suspended together with the original load to enable the lifting operation to take place.
- 7 Ensure that all mechanisms on 'SUPERCLAMP' products are working freely before being used for the application intended.
- 8 Never replace worn components unless these are original 'SUPERCLAMP' parts. Where products are fitted with replaceable jaws, incorporating teeth showing wear, it is strictly prohibited to recut or resharpen these. Cams or jaws incorporating teeth can be easily replaced with original 'SUPERCLAMP' components available from your approved 'SUPERCLAMP' distributor.
- 9 Always ensure that repaired products are inspected and re-tested in accordance with the laws of your country prior to being released for operation.
- 10 Ensure that all persons using 'SUPERCLAMP' equipment are properly trained in performing lifting operations and competently using this type of equipment.

- 11 If multipoint lifting operations are undertaken, always ensure that no single point of lift is at any time required to exceed its maximum Work Load Limit.
- 12 Never throw or drop 'SUPERCLAMP' equipment, as this may well be hazardous or injure people or plant.
- 13 If in doubt about the suitability of 'SUPERCLAMP' products for your application, then contact your nearest supervisor.
- 14 Your nearest 'SUPERCLAMP' distributor will advise you on applications if required.

SPECIAL PRODUCTS

Our drawing office is staffed by experienced Design Engineers who can solve your most difficult problems.

SPECIALS

- 1 Spark Proof Girder Clamps and Trolleys.
- 2 Anti-Corrosive Girder Clamps and Trolleys.
- 3 Man Carrying Girder Clamps and Trolleys.
- 4 Low Headroom Clamps.
- 5 Clamps and Trolleys with Non-Standard Working Load Limits.
- 6 Clamps and Trolleys to suit Customer Requirements.

NOTES

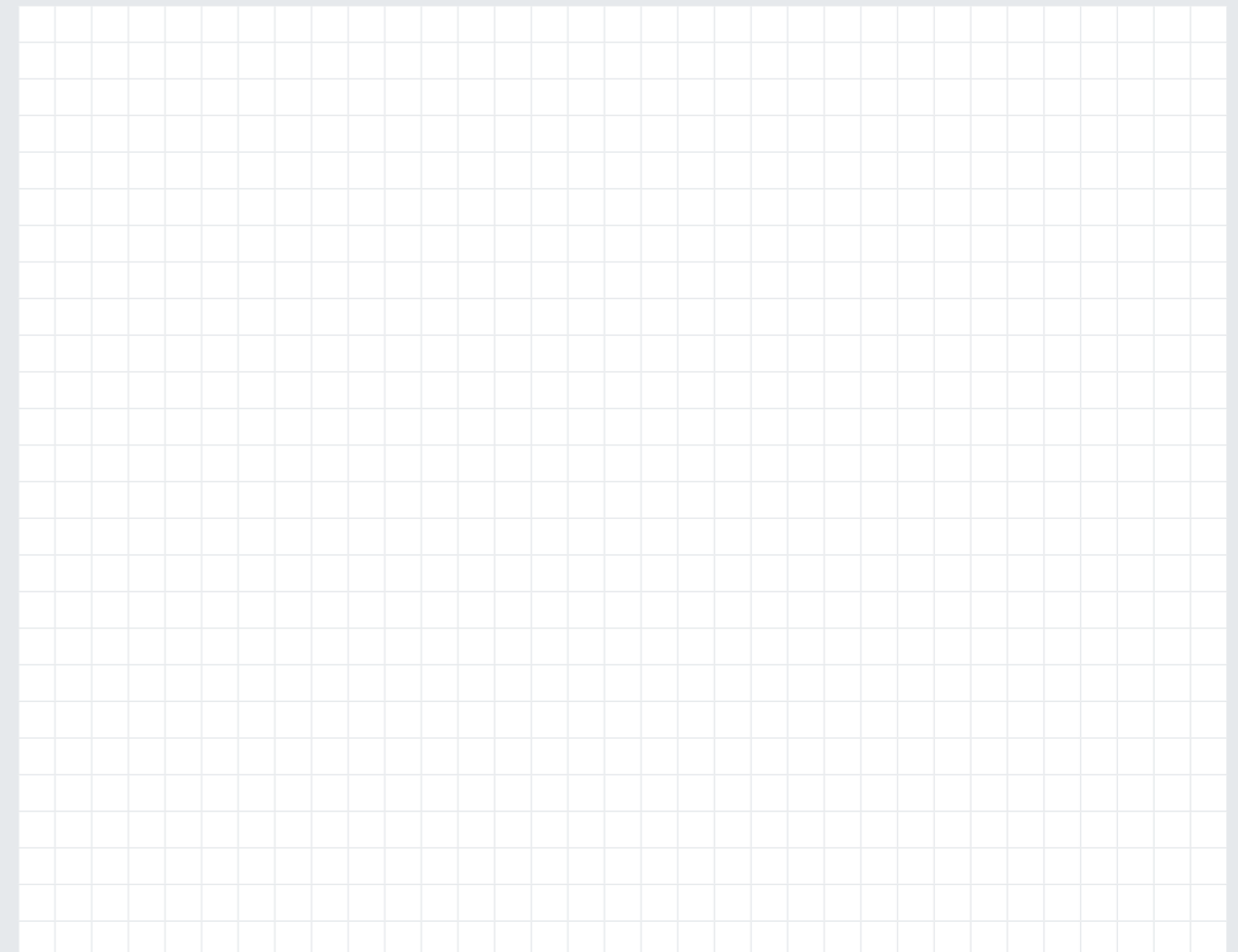

Riley (Lifting Equipment) Ltd

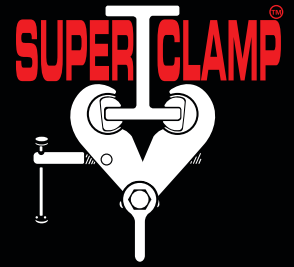

Hope Building, Dockray Street, Colne, Lancashire BB8 9HT

Tel: +44 (0) 1282 867 177 Fax: +44 (0) 1282 863 698

Email: info@superclamp.co.uk www.superclamp.co.uk



- **Safe**
- **Versatile**
- **Easy to Install**
- **Adjustable**
- **Inexpensive**
- **Solves all lifting problems in all areas of maintenance**

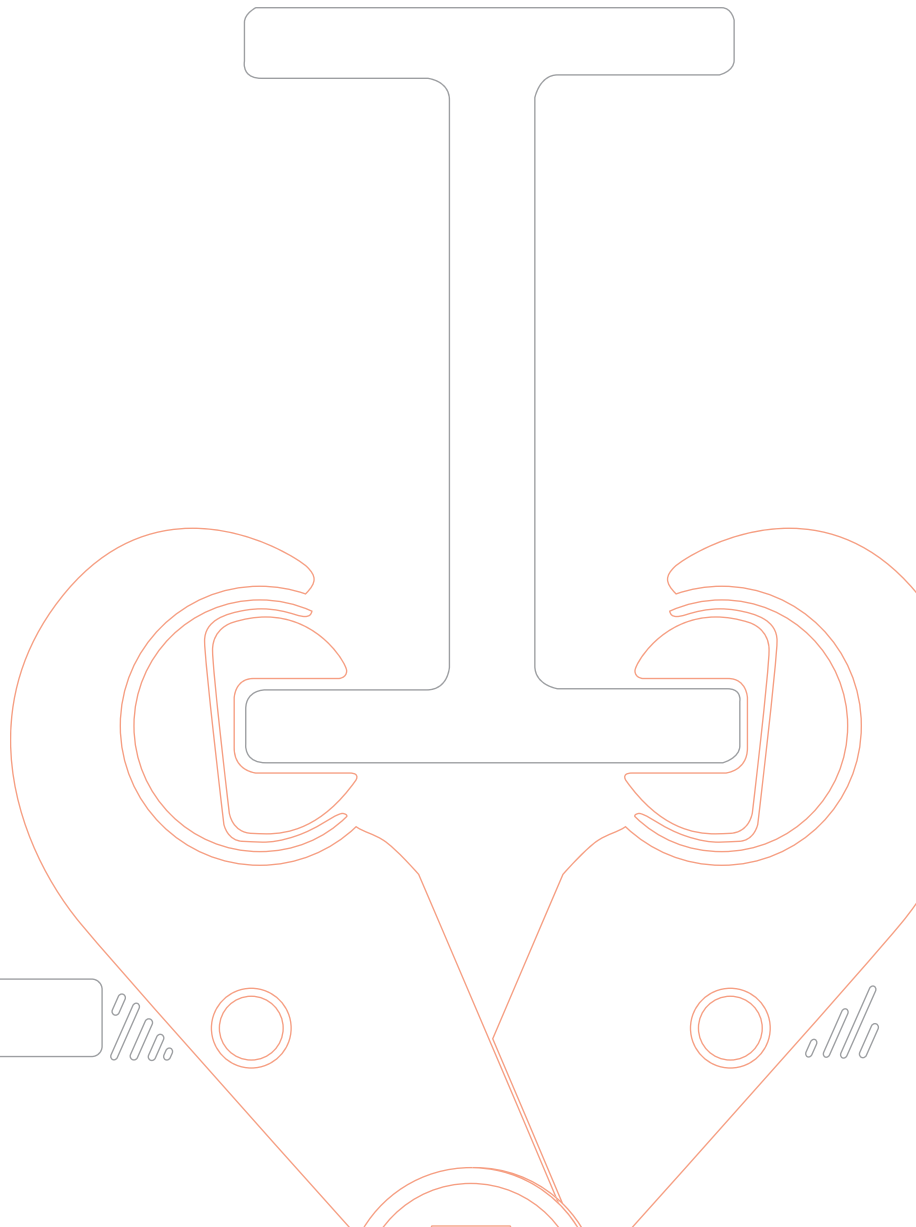

Lifting Equipment
Engineers Association